

# SCAN COIN

## Coin Conveyor Systems

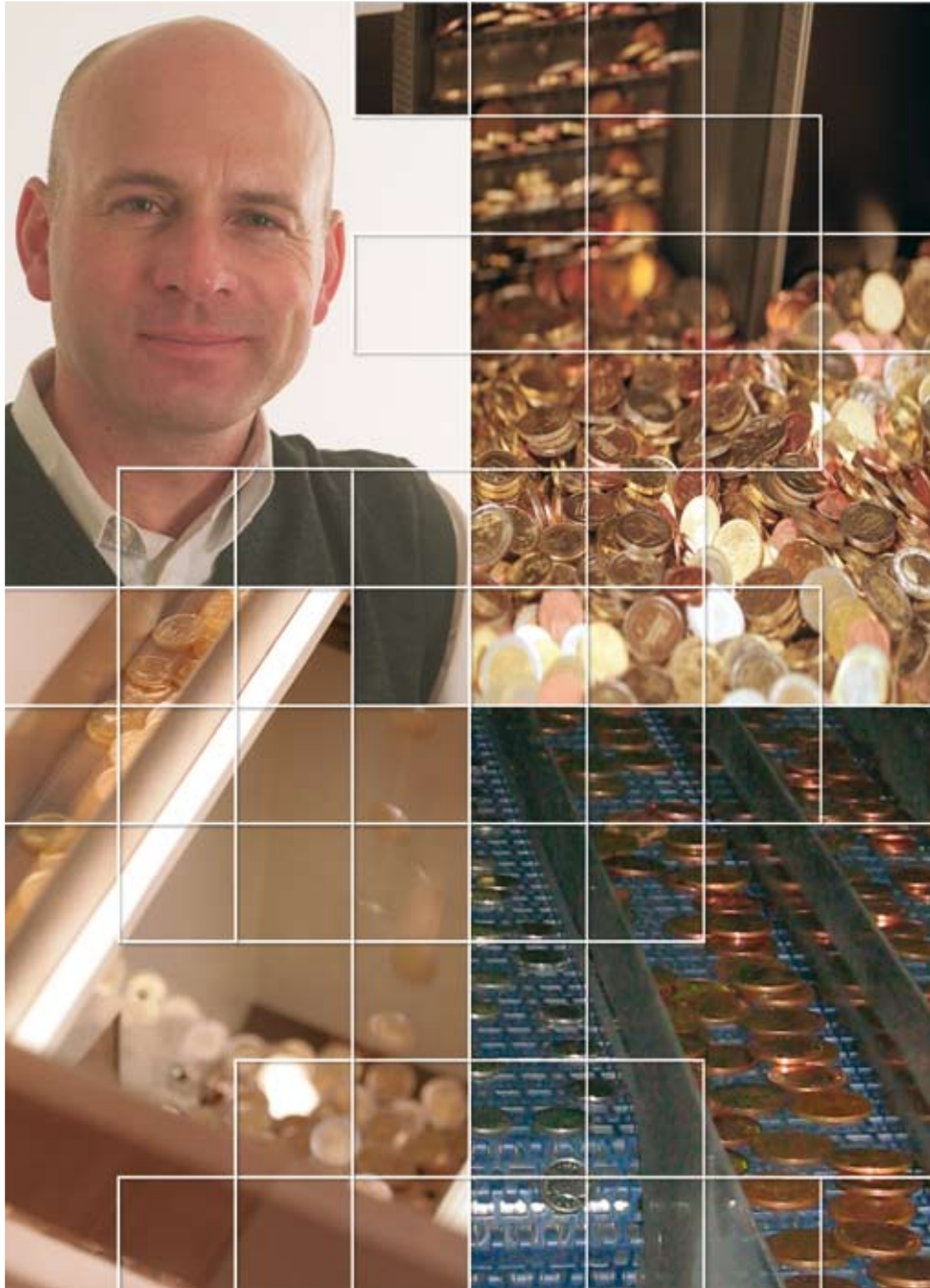

# Conveyor System SC 93770

Handles large quantities of coins after they have been sorted by coin sorter SC Active 4000. Coins from the coin sorter fall down onto conveyors transporting each denomination to its specific coin wagon SC 93400.

Transparent covers (for inspection) reduce noise level for increased comfort and can be lifted for easy access. Choose a system for two, four, six or eight denominations.

Coin wagons are not included and have to be ordered separately.

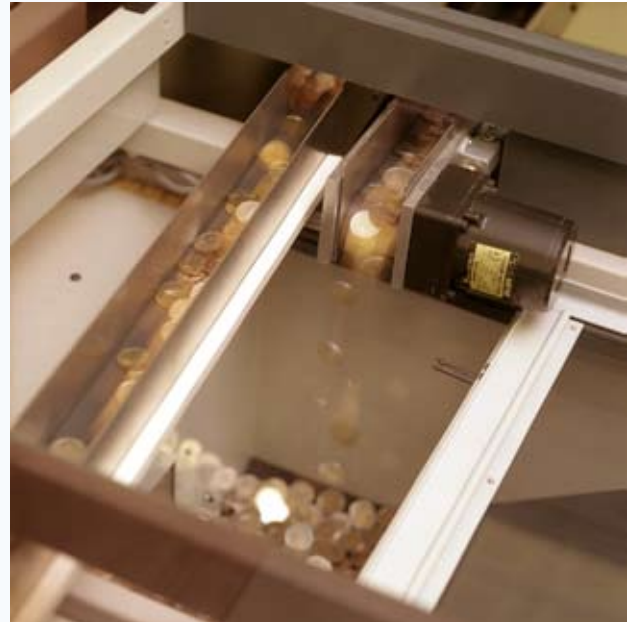

| TECHNICAL SPECIFICATIONS |                               |
|--------------------------|-------------------------------|
| Height:                  | 800 mm (31.50")               |
| Width:                   | 1,600 mm (62.99")             |
| Depth:                   | 630 - 2,300 mm (24.80-90.55") |

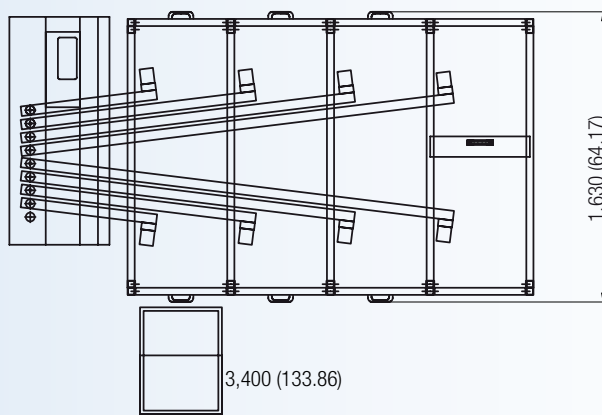
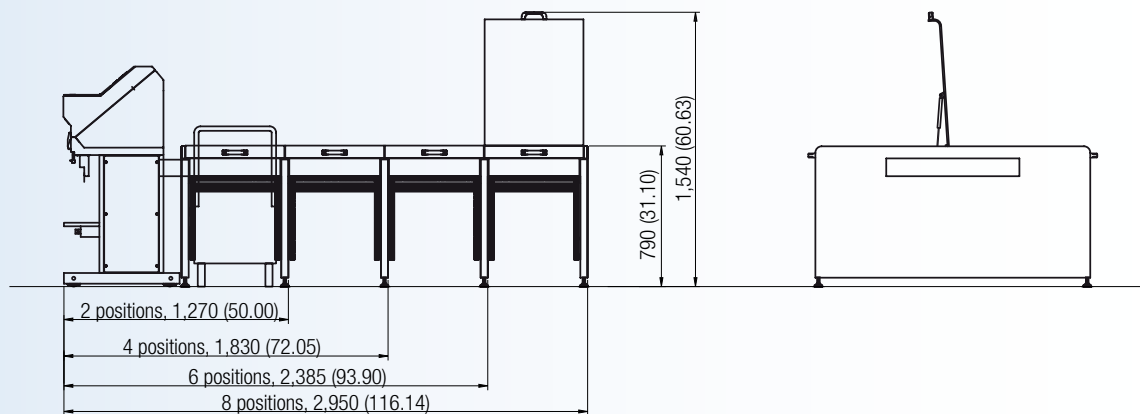

Dimensions in mm (inches)

# Multi Lane Conveyor System SC 95800

The Multi Lane Conveyor system SC 95800 (MLC) handles large quantities of coins after they have been sorted by two, three or four SC Active 4000 machines that are working together. The basic configuration is for two SC Active 4000 machines.

A master PC (included) coordinates all SC Active 4000 to have an accurate batch stop. Coins from the SC Active 4000 fall down onto conveyors, transporting each denomination to its specific cage or coin wagon (SC 93400).

Saves space compared with single installations. The system is easily operated and monitored on a PC-screen by the operator.

Coin cages and wagons are not included and have to be ordered separately.



| TECHNICAL SPECIFICATIONS                                |  |
|---|--|
| Height  | 1,223 mm (48.1") SC Active 4000 inlet                                    |
| Width   | 2,240 mm (88.2")   |
| Depth*  | 9,500 mm (374.0") with coin wagons<br>11,000 mm (433.1") with coin cages |
| *) Depending on the number of SC Active 4000 connected. |  |

Dimensions in mm (inches)

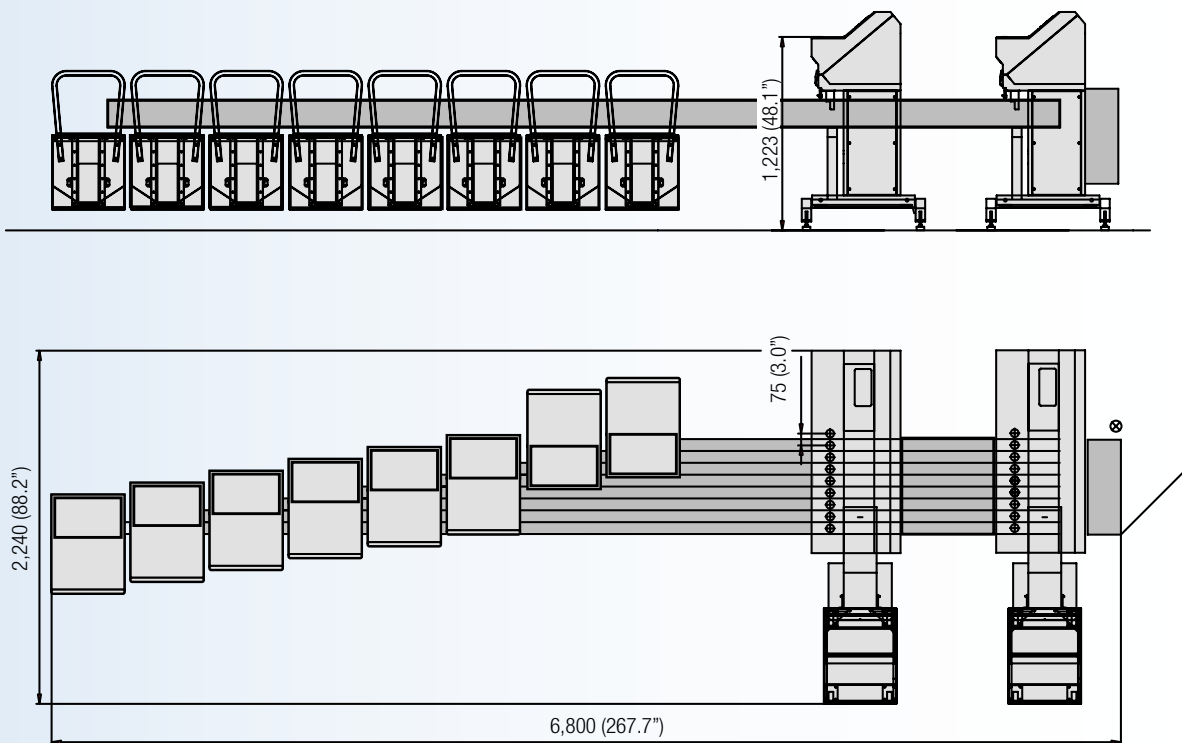

## Before and after...



The SC Active 4000 coin sorter counts and sorts coins in up to eight outlets.

Before the installation of the multi lane conveyor system SC 95800, the sorted coins were collected in large bags. There was no automatic monitoring of the system.

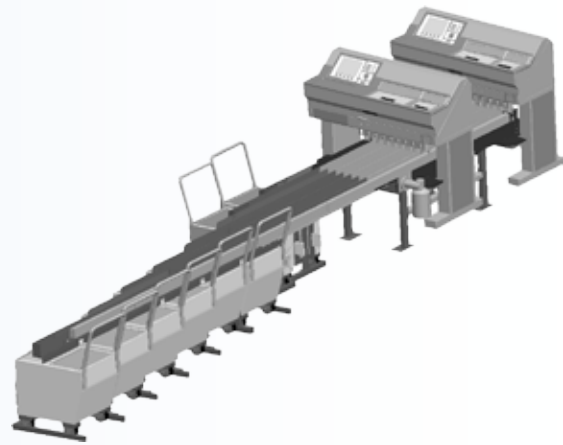

With the multi lane conveyor system SC 95800 the line is now easy to supervise and control. The SC 95800 and the SC Active 4000 interact so that stop time is reduced to a minimum.

Operators are relieved from heavy lifting and repetitive motions, such as bending down to change coin bags.

An efficient, smooth-running coin handling system is a smart investment that helps you control costs, and keep accurate accounts – which in turn has a positive effect on total profit management.

Founded in 1966, SCAN COIN is one of today's leading suppliers of cash processing equipment, system solutions and services. Our worldwide customer base is served through a network of SCAN COIN companies and distribution partners covering some 120 countries. SCAN COIN develops, manufactures and markets equipment and integrated solutions for handling banknotes and coins, and has become a world leader in the automatic cash processing market.

# SCAN COIN

SCAN COIN Intramat AB, Skutholmsvägen 7, SE-471 41 Rönnäng, Sweden

Phone int. +46 304 67 40 80, Fax int. +46 304 67 04 02

E-mail: [info@scancoin.se](mailto:info@scancoin.se), Internet: [www.scancoin.com](http://www.scancoin.com)

#### SCAN COIN COMPANIES

SCAN COIN (Head Office)  
SCAN COIN Svenska AB  
SCAN COIN A/S  
SCAN COIN A/S  
SCAN COIN Ltd.  
SCAN COIN Ireland Ltd.  
SCAN COIN-PERCONTA GmbH  
SCAN COIN North America Inc.  
SCAN COIN S.L.  
SCAN COIN Ltd.  
SCAN COIN Italia s.r.l.  
SCAN COIN-Borsu Systema B.V.  
SCAN COIN Belgium  
France Espèces SAS  
ServiCash Lda.

#### ADDRESS

Jägerhillgatan 26, SE-213 75 Malmö, Sweden  
Gustav III:s boulevard 46, SE-169 73 Solna, Sweden  
Rosenholmveien 25, NO-1410 Kolbotn, Norway  
Smedeland 6, DK-2600 Glostrup, Denmark  
Dutch House, 110 Broadway, Salford Quays, M50 2UW, UK  
Bracetown Business Park, Clonee, Co Meath, Ireland  
Sylvesterallee 2, DE-225 25 Hamburg, Germany  
20145 Ashbrook Place, Suite 110, Ashburn VA 20147-3375, USA  
Tomas Bretón, 31-35 Local 7, 08950 Esplugues de Llobregat, Barcelona, Spain  
Room 1301-2, 13/F, Easey Commercial Building, 253 - 261 Hennessy Road, Wanchai, HONG KONG  
Via Vittorio Veneto 8, IT-20091 Bresso (Milano), Italy  
Van Weerden Poelmanweg 23, NL-3768 MN Soestduinen, The Netherlands  
4, rue de la Presse, BE-1000 Bruxelles, BELGIUM  
10, rue de Temara, B.P. 8266, FR-78108 Saint-Germain-en-Laye Cedex, France  
Rua Campos Junior, 7-A, PT-1070-306 Lisboa, Portugal

#### PHONE

+46 40 600 06 00  
+46 8 555 282 00  
+47 66 81 34 00  
+45 43 63 06 44  
+44 161 873 0500  
+353 1 801 4077  
+49 40 547 6130  
+1 703 729 8600, 800 336 3311 (Toll free)  
+34 902 446 777  
+852 2590 6438  
+39 02 610 11 47  
+31 35 603 98 88  
+32 2 223 75 30  
+33 1 39 04 05 50  
+351 21 760 90 44

#### E-MAIL

[info@scancoin.se](mailto:info@scancoin.se)  
[info@swe.scancoin.se](mailto:info@swe.scancoin.se)  
[info@scancoin.no](mailto:info@scancoin.no)  
[info@scancoin.dk](mailto:info@scancoin.dk)  
[sales@scancoin.co.uk](mailto:sales@scancoin.co.uk)  
[sales@scancoin.ie](mailto:sales@scancoin.ie)  
[info@scancoin.de](mailto:info@scancoin.de)  
[inquiry@scancoin-usa.com](mailto:inquiry@scancoin-usa.com)  
[info@scancoin.es](mailto:info@scancoin.es)  
[clam@scancoin.com.hk](mailto:clam@scancoin.com.hk)  
[info@scancoin.it](mailto:info@scancoin.it)  
[info@scbs.nl](mailto:info@scbs.nl)  
[infos@france-especes.fr](mailto:infos@france-especes.fr)  
[infos@france-especes.fr](mailto:infos@france-especes.fr)  
[servicash@mail.telepac.pt](mailto:servicash@mail.telepac.pt)